

# Abri-voitures en metal

## «Couv'voiture 35»

Manuel du propriétaire/  
Instructions pour l'assemblage de l'abri « Couv'voiture 35 »

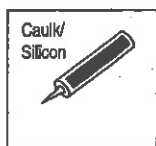
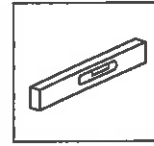
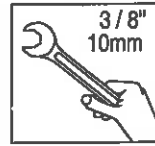
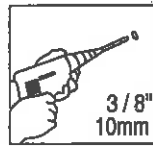
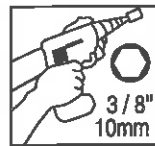
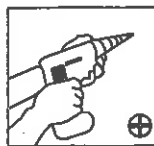
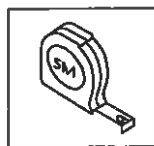
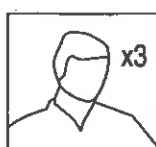

## Préparation de l'assemblage

Vérifiez les codes locaux concernant les semelles, l'emplacement et d'autres exigences locales avant le début de la construction. Comprenez que ce manuel d'informations est important pour le propriétaire et délivre des conseils utiles pour un assemblage plus facile et plus agréable.

## Instructions de montage

Avant de commencer, assurez-vous de suivre les étapes soigneusement pour des résultats réussis.

## Liste des pièces

Vérifiez pour être sûr que vous avez toutes les pièces nécessaires.

## La sécurité doit être mise dans la position n ° 1

1. Choisissez un jour sec et calme pour votre construction. Ne tentez pas d'assembler le carport si vous êtes fatigué, si vous avez pris des médicaments, des drogues ou de l'alcool, ou si vous êtes sujet à des vertiges.
2. Des travaux d'équipe (trois personnes ou plus) sont requis pendant l'assemblage.
3. Portez des gants de sécurité, des chaussures, des lunettes de protection et des manches longues pendant le montage pour prévenir les blessures. Faites attention au bord tranchant de certaines pièces.
4. Les enfants et les animaux domestiques ne sont pas autorisés à entrer dans le chantier de construction. Jetez tous les sacs plastiques en toute sécurité - gardez-les hors de portée des enfants en bas âge.
5. Lorsque vous utilisez un escabeau ou des outils électriques, assurez-vous que vous respectez les conseils de sécurité du fabricant.
6. Ne pas grimper ou ne pas se tenir debout sur le toit.
7. De grandes quantités de neige sur le toit peuvent endommager l'abri, ce qui rend peu sécuritaire de se tenir en dessous ou à proximité.
8. Les articles lourds ne doivent pas être appuyés contre les poteaux.
9. Ce produit a été conçu pour être utilisé principalement comme abri de voiture.

## Entretien et maintenance

1. Panneaux de PC: exposez seulement le côté imprimé d'un masquage à la lumière du soleil - ce côté est protégé contre les rayons UV.
  2. Gardez le toit et les gouttières sans neige, saleté et feuilles.
  3. Lors du nettoyage, utilisez une solution détergente douce et rincez avec de l'eau propre et froide.
- N'utilisez pas d'acétone, de nettoyeurs abrasifs ou d'autres produits détergents pour nettoyer le panneau.

## Avant le montage

Ce carport doit être assemblé sur une base solide (béton ou asphalte).

La surface des bases sous les pôles doit être de niveau.

Pendant l'assemblage, utilisez une plate-forme souple sous les pièces pour éviter les rayures et les dommages.

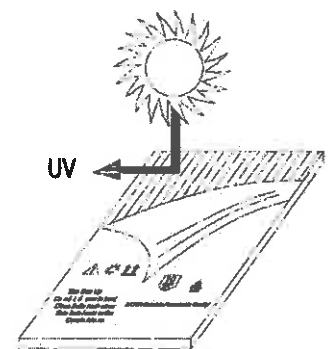

# Taille du Couv'voiture 35

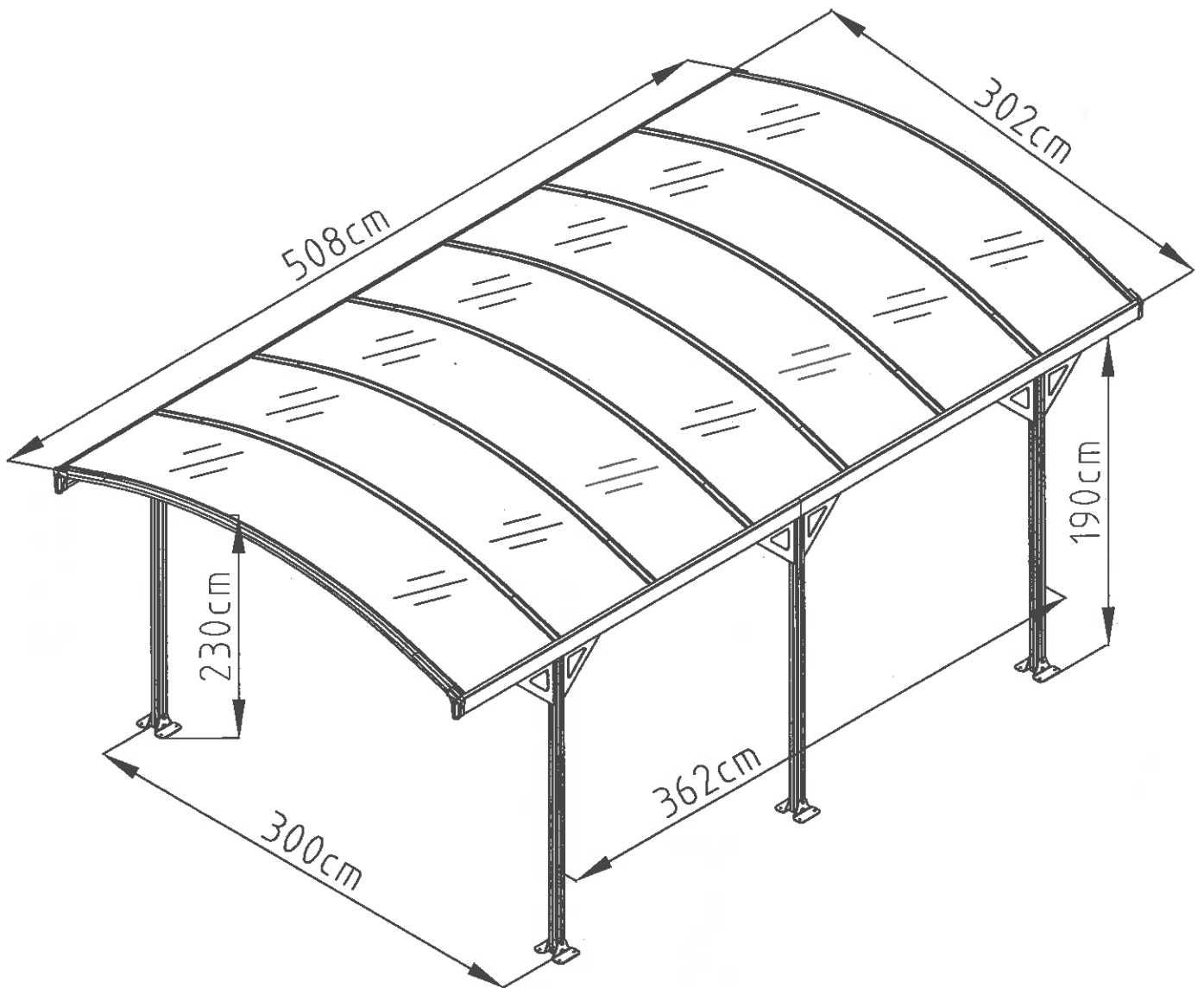

## Zone d'installation requise

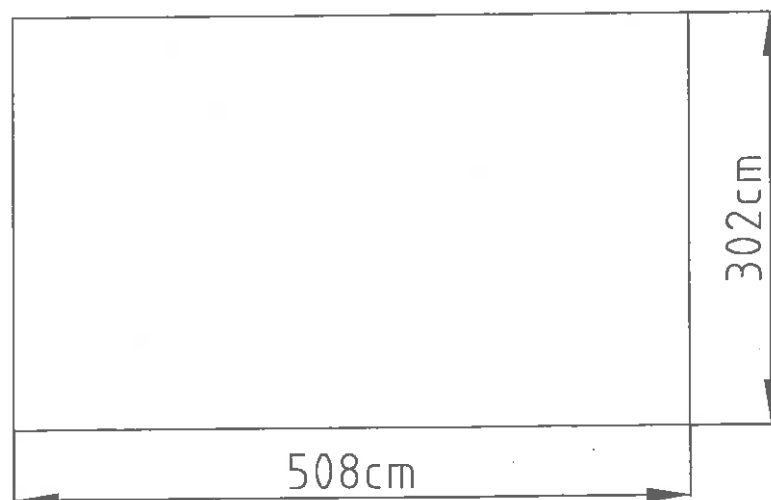

**Ce carport doit être assemblé sur une base solide (comme du béton). Sans base solide, la pré-fondation, qui inclut du béton et du métal, est nécessaire comme dessins suivants.**

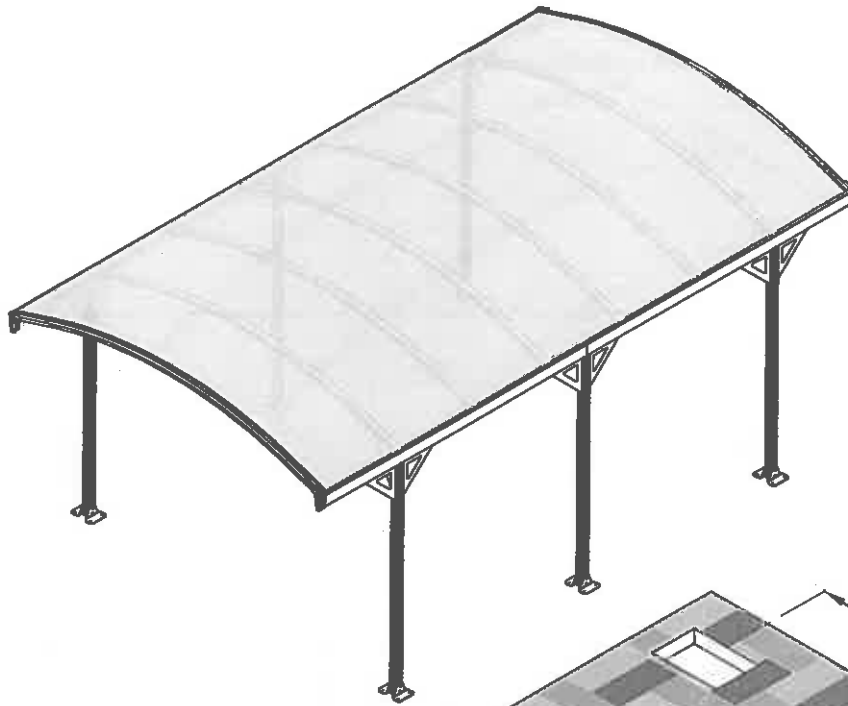

**Pierre de chaussée**

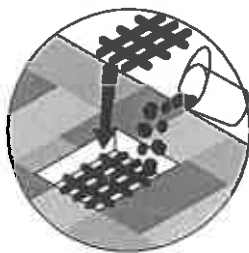
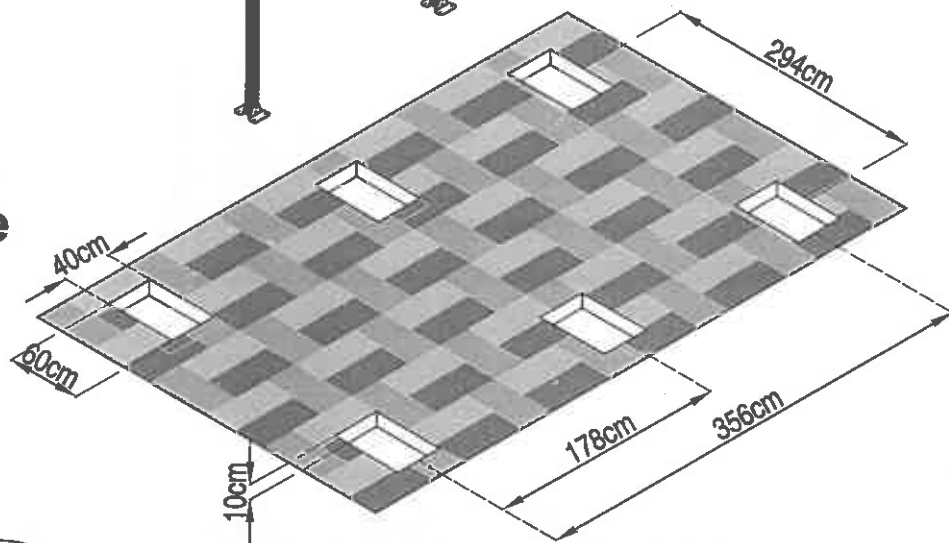

**x 6**

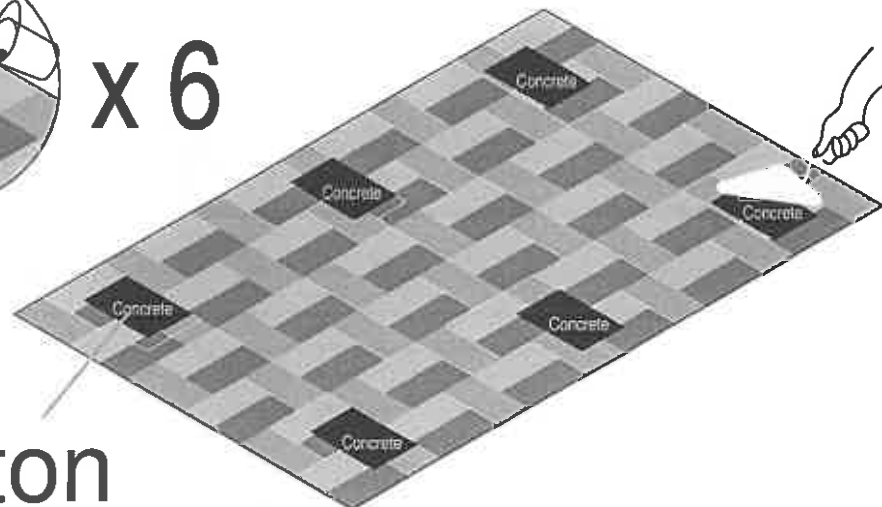

**béton**

# OU

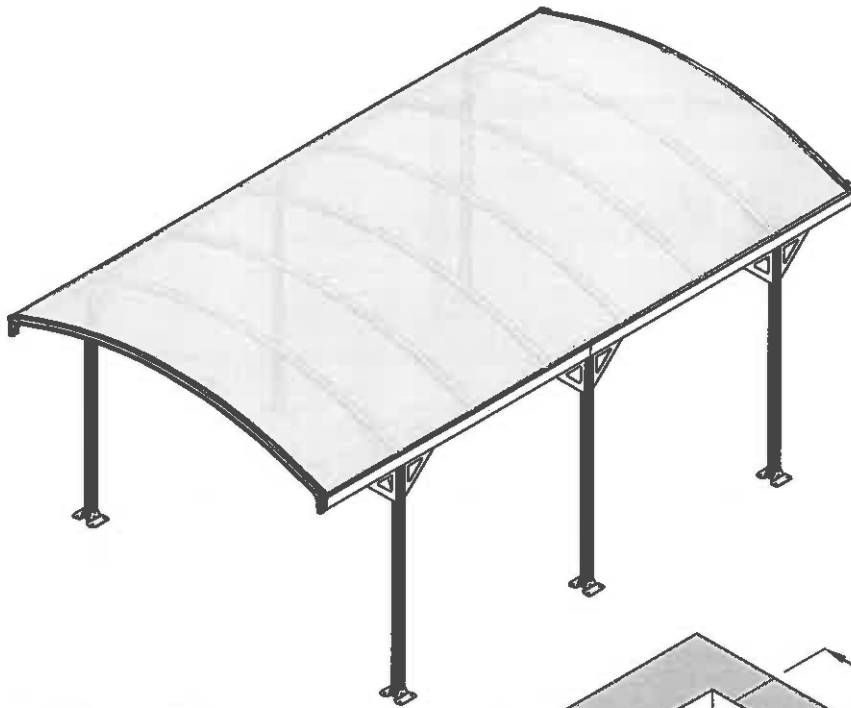

## Asphalt /terre

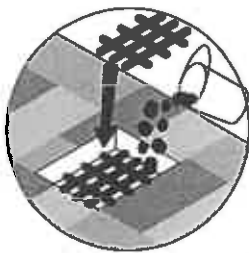
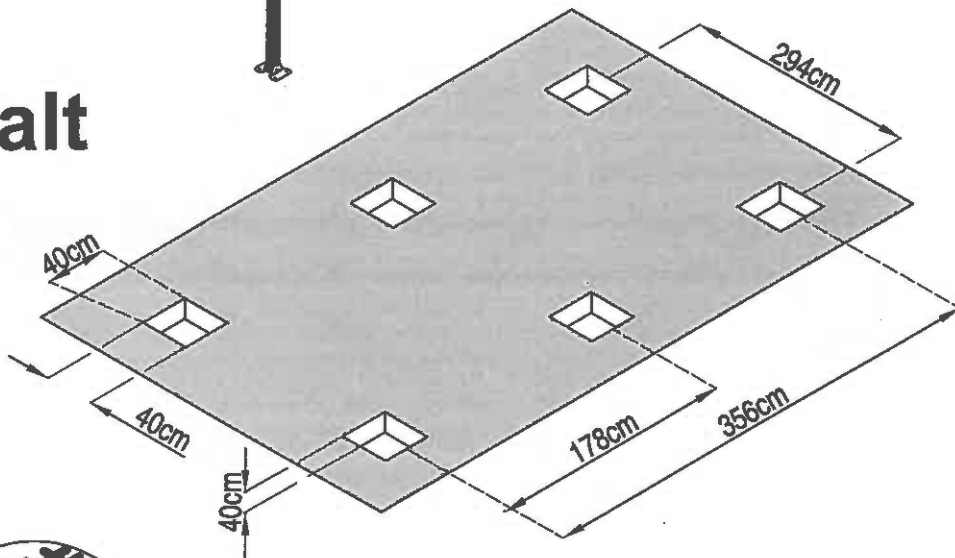

### x 6

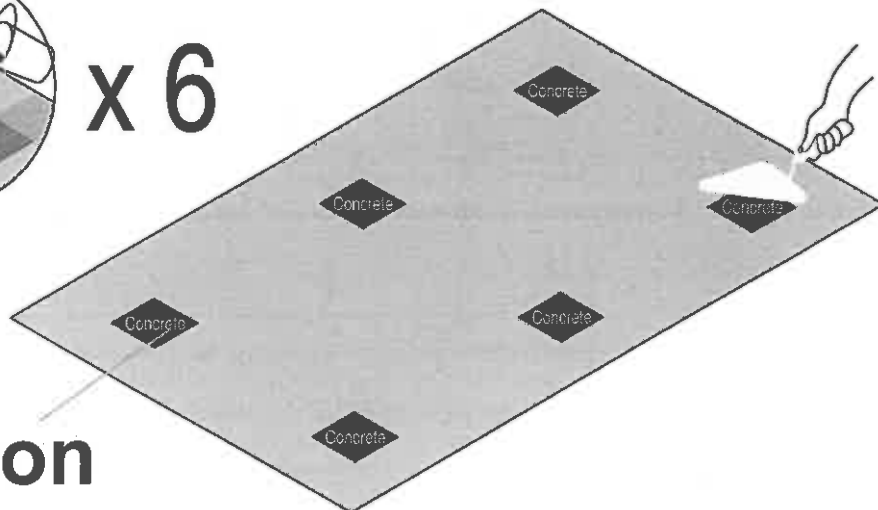

## béton





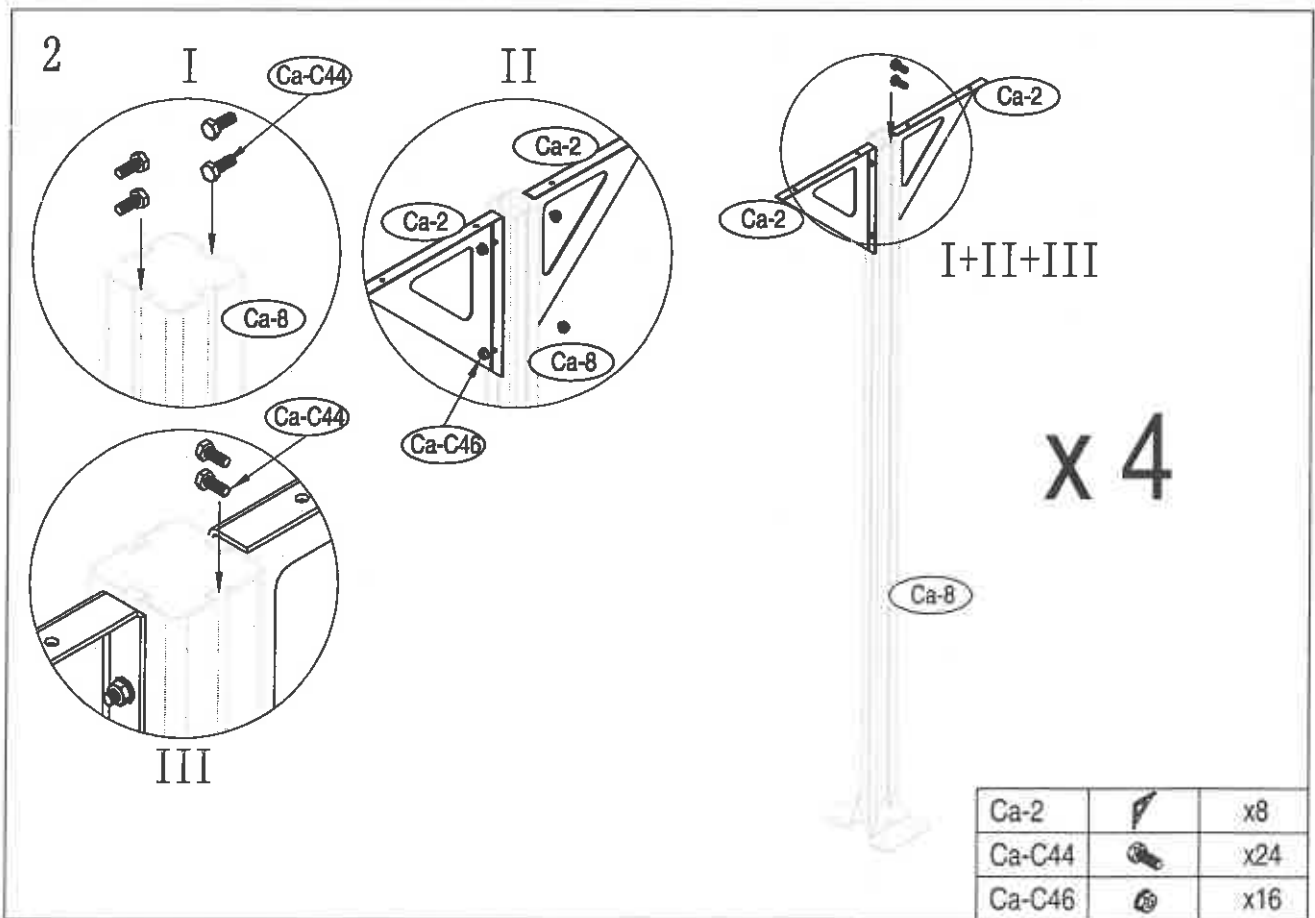
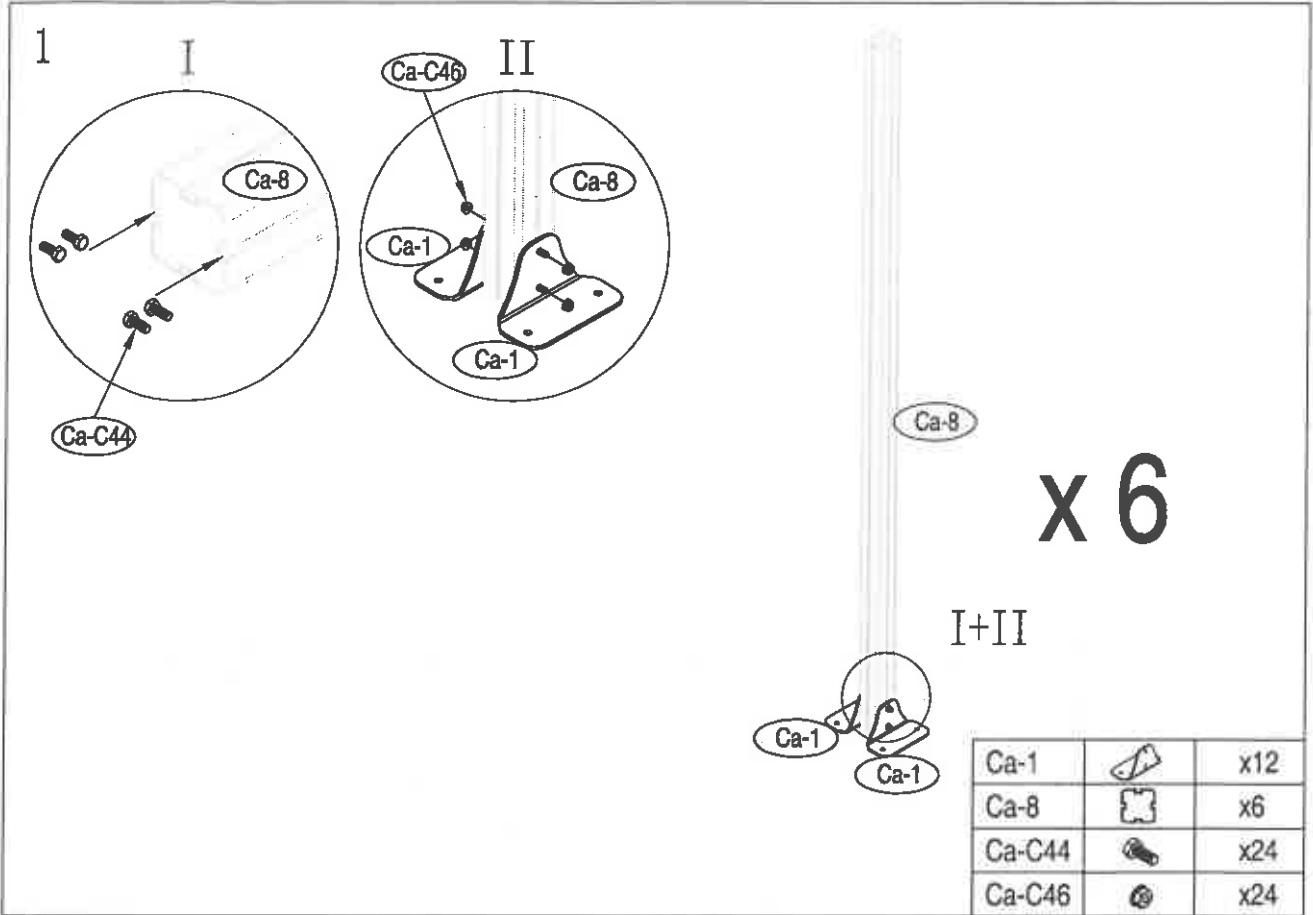



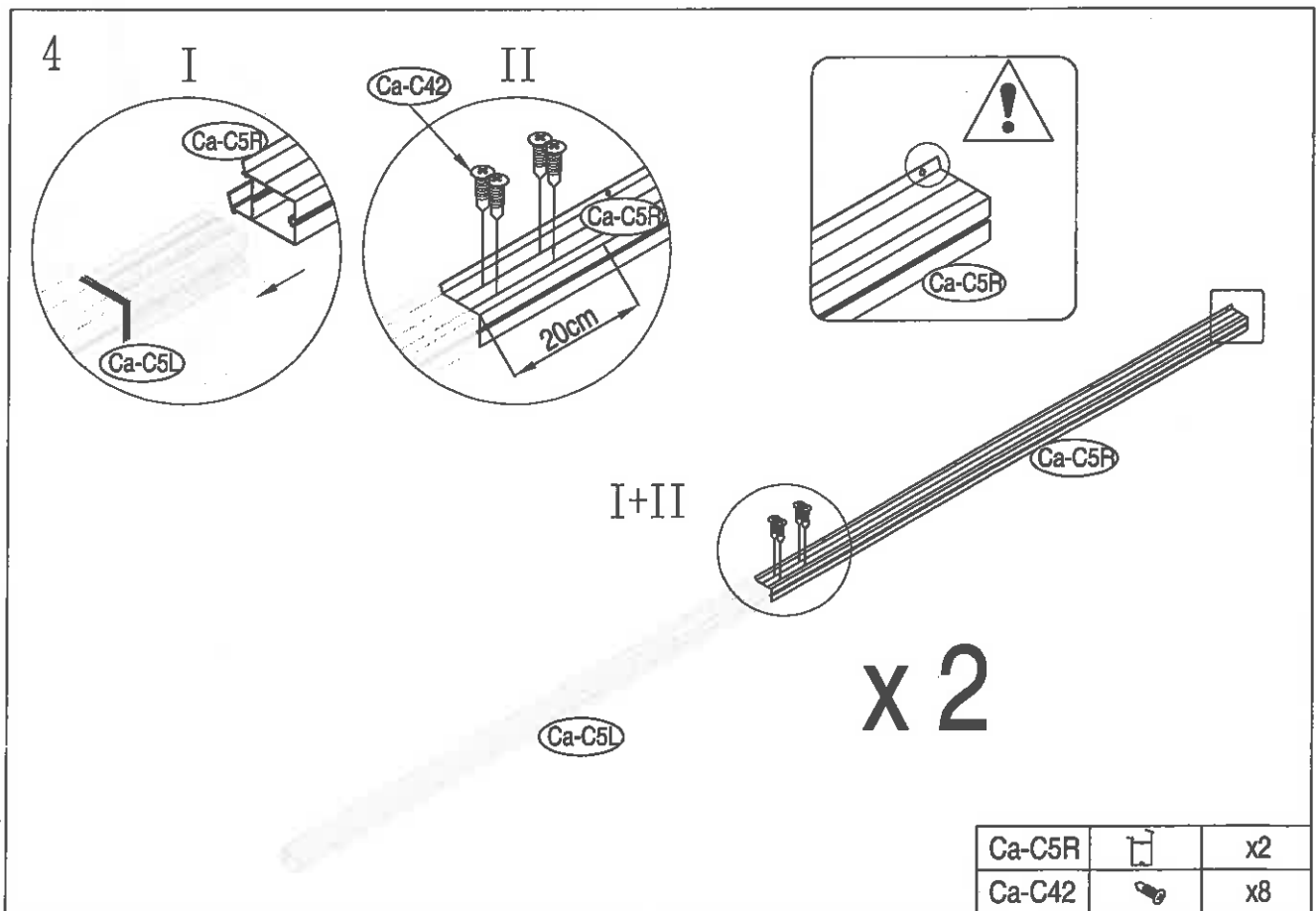
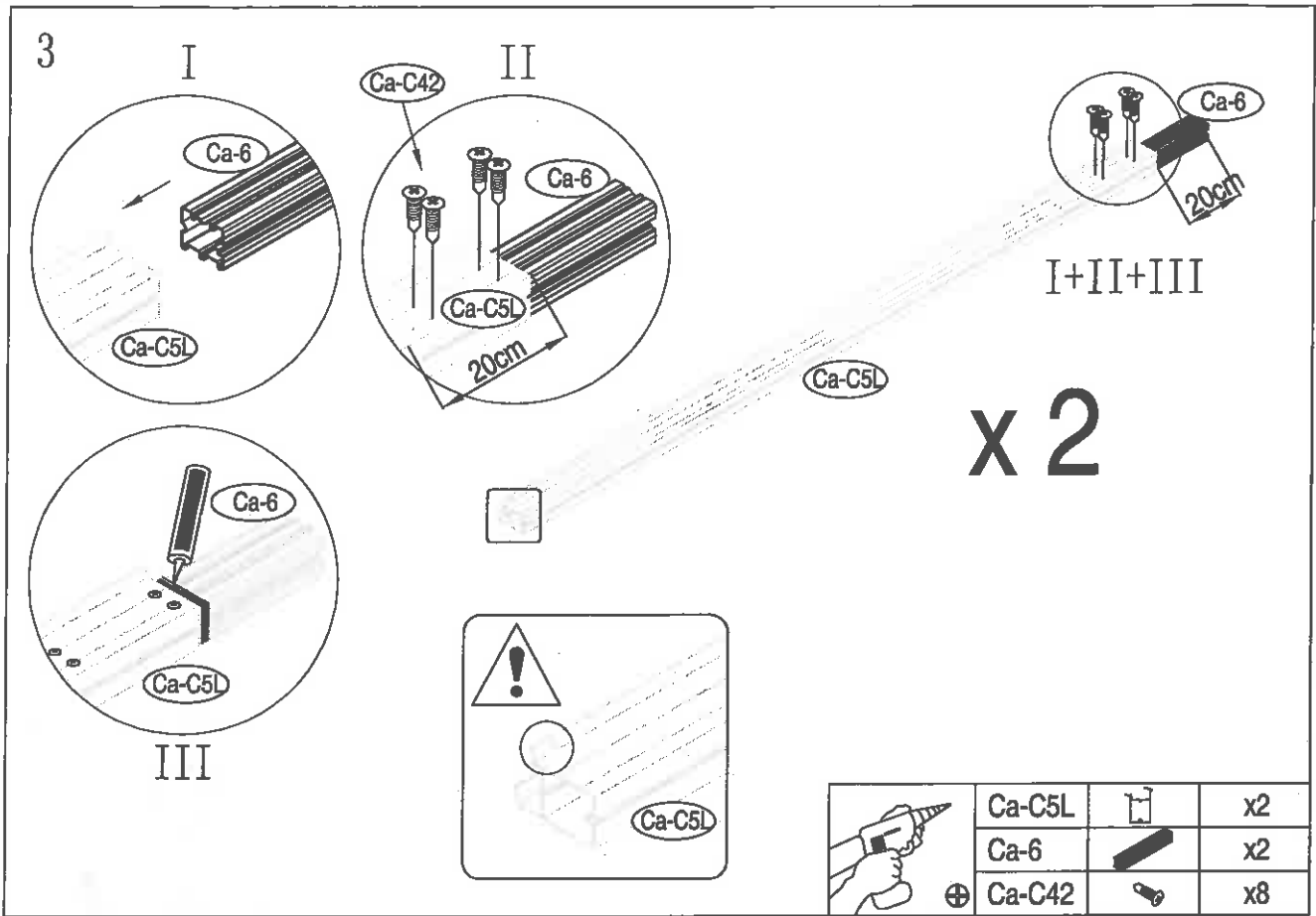

2



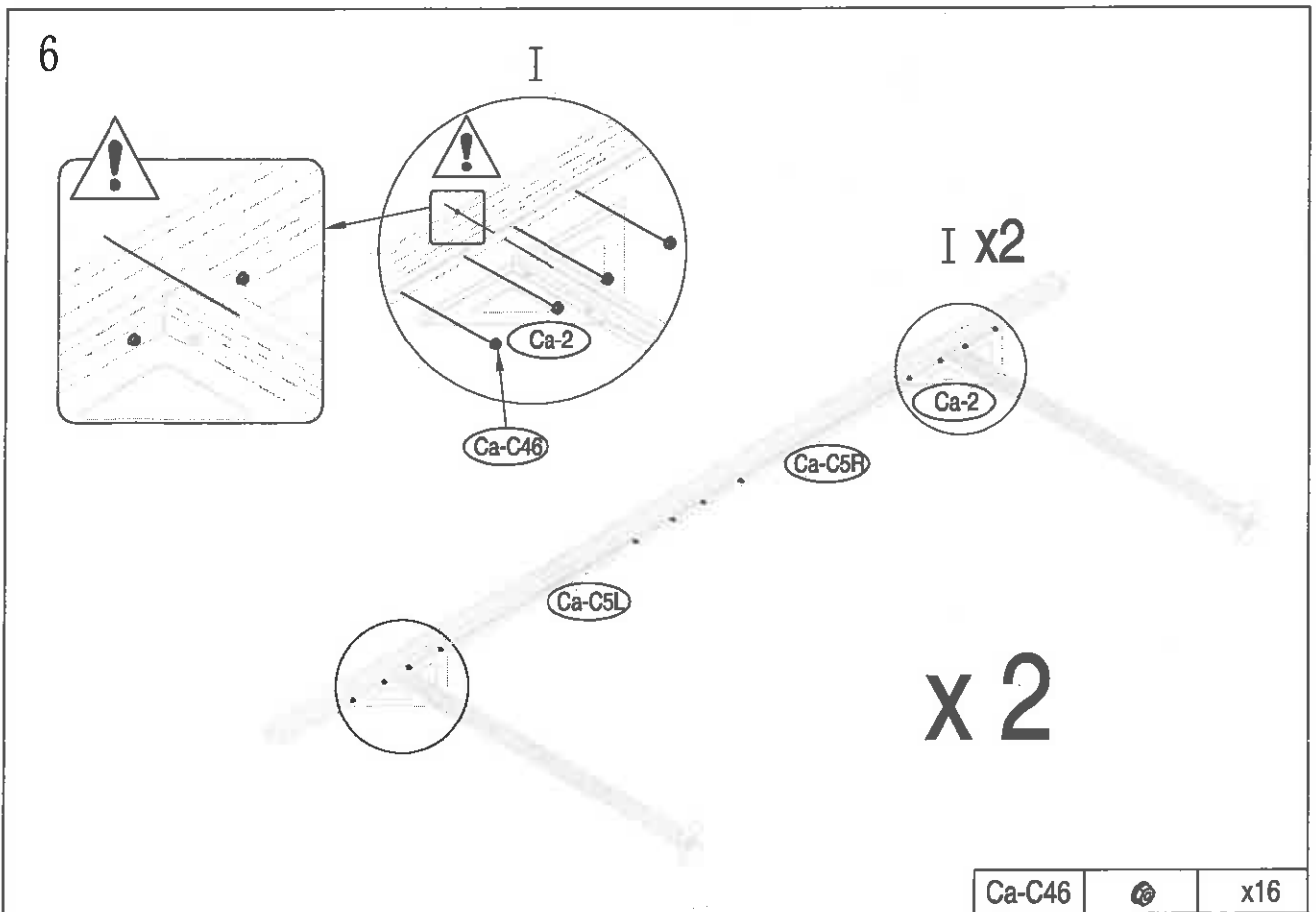
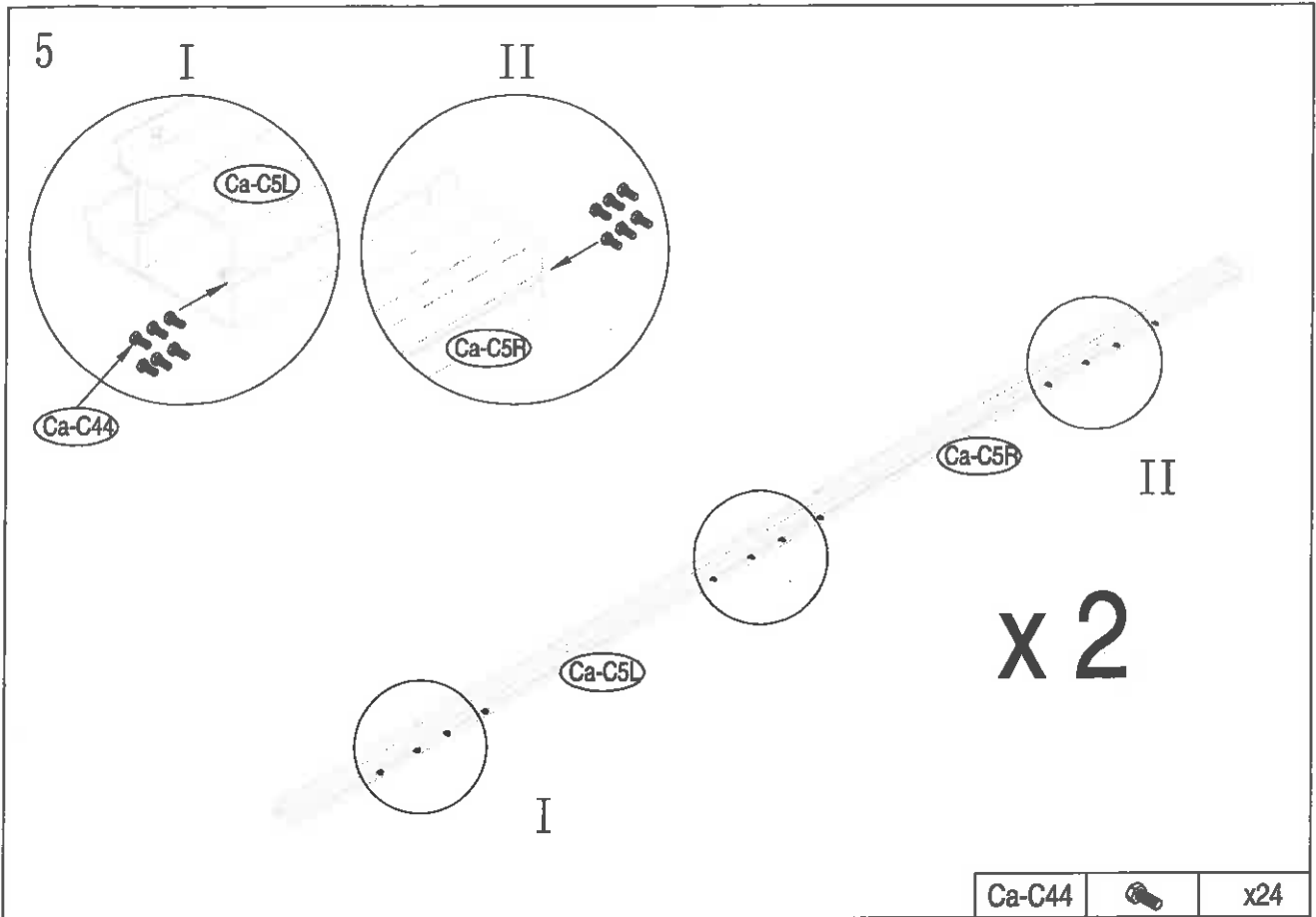

3



7

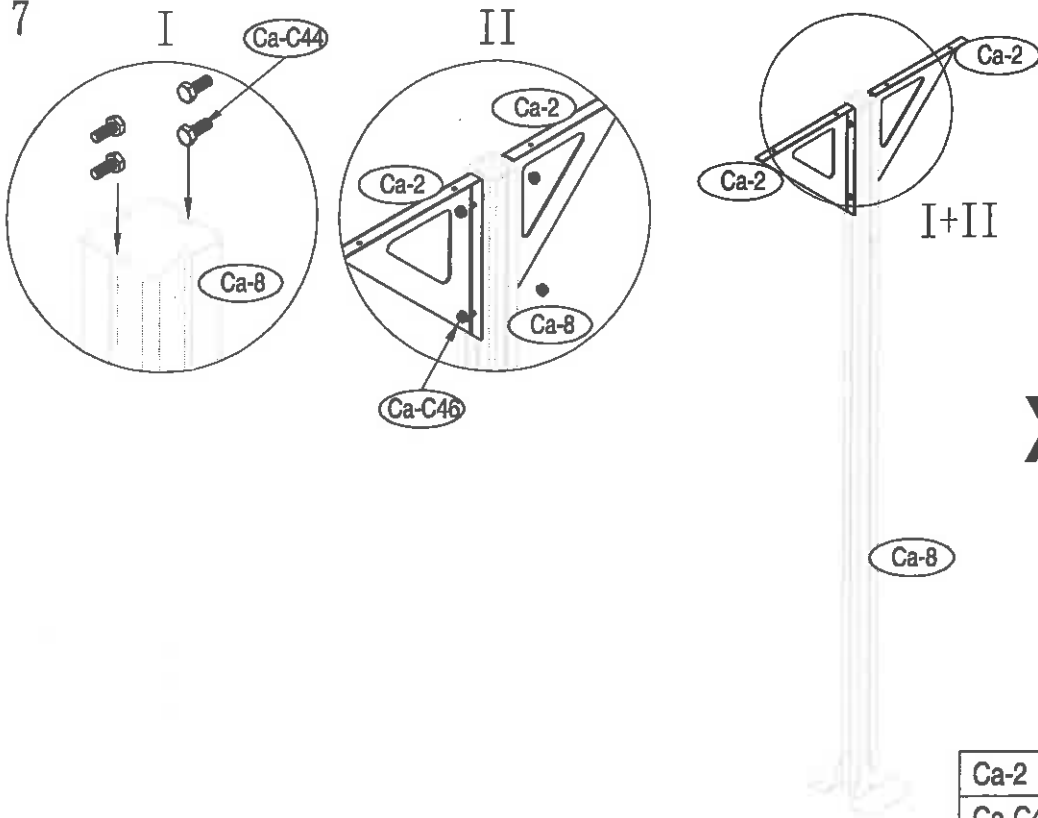

Ca-2		x4
Ca-C44		x8
Ca-C46		x8

8

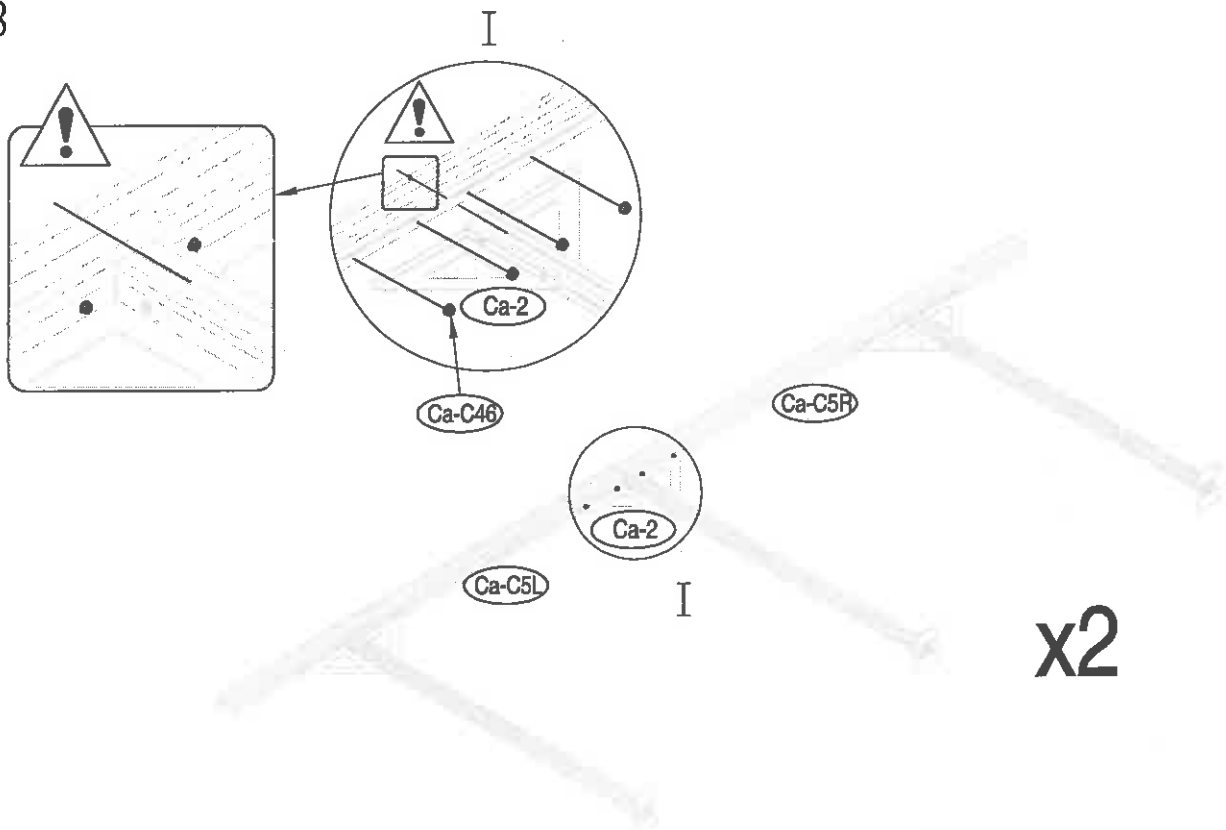

Ca-C46		x8
--------	--	----

4



9



I+II

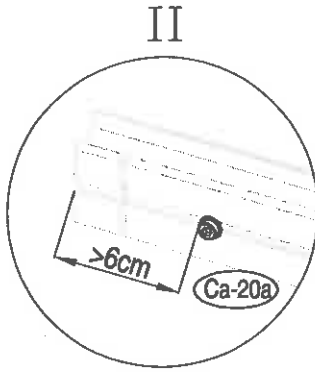
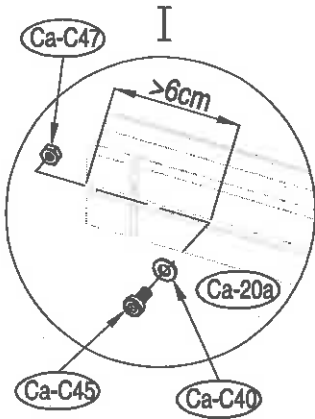

Ca-20a

x2

I+II

Ca-20a		x2
Ca-C40		x4
Ca-C45		x4
Ca-C47		x4



10

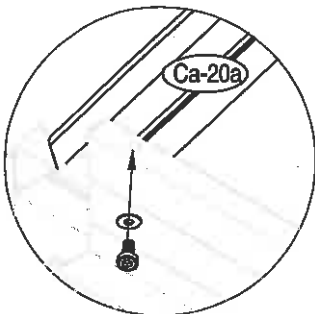
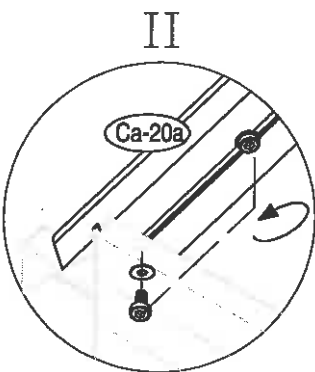
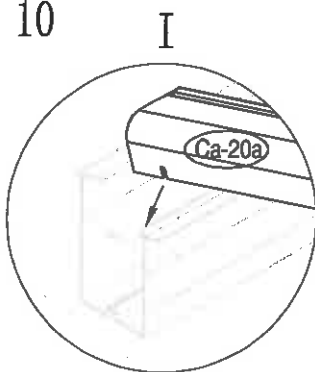

III

I+II+III

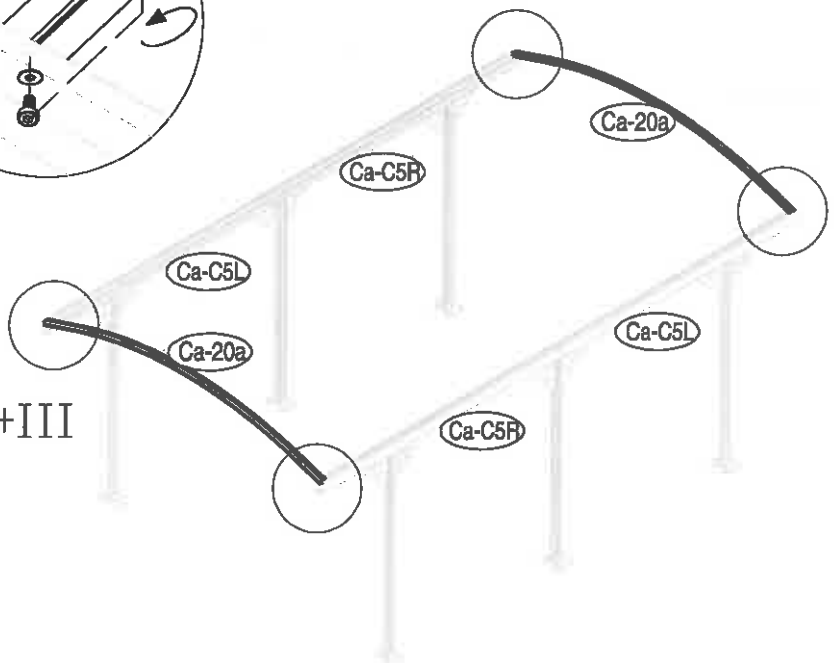

5



11

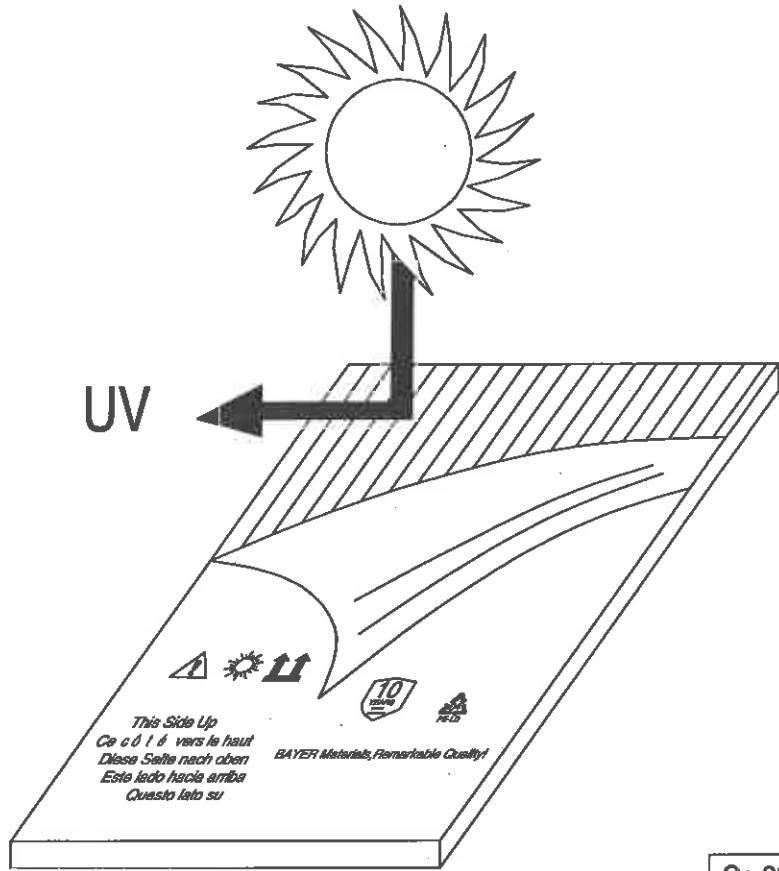

Ca-23a  x7

12

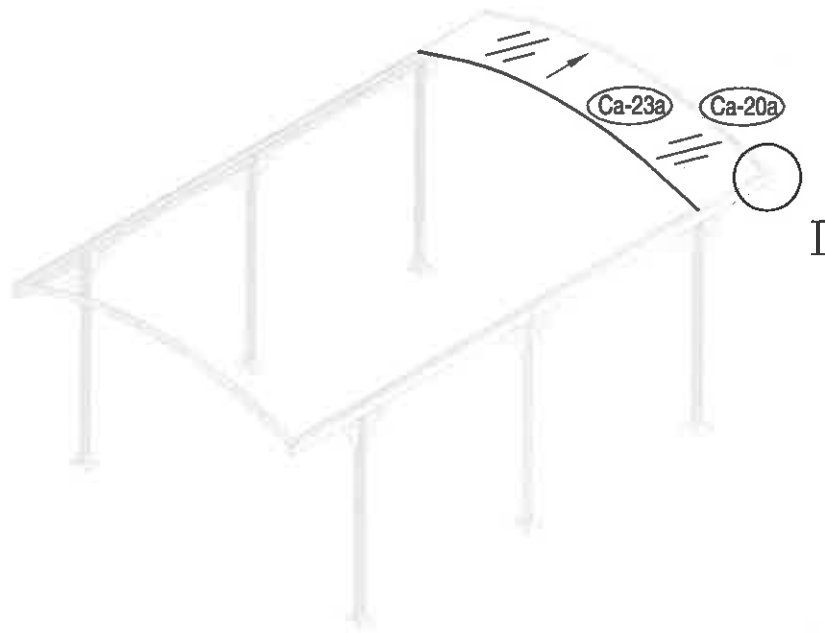
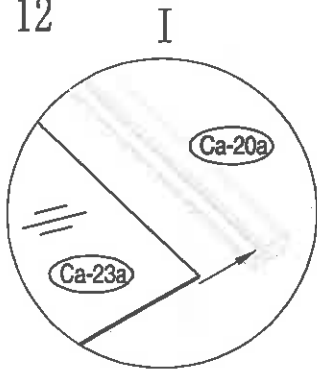

Ca-23a  x1

6



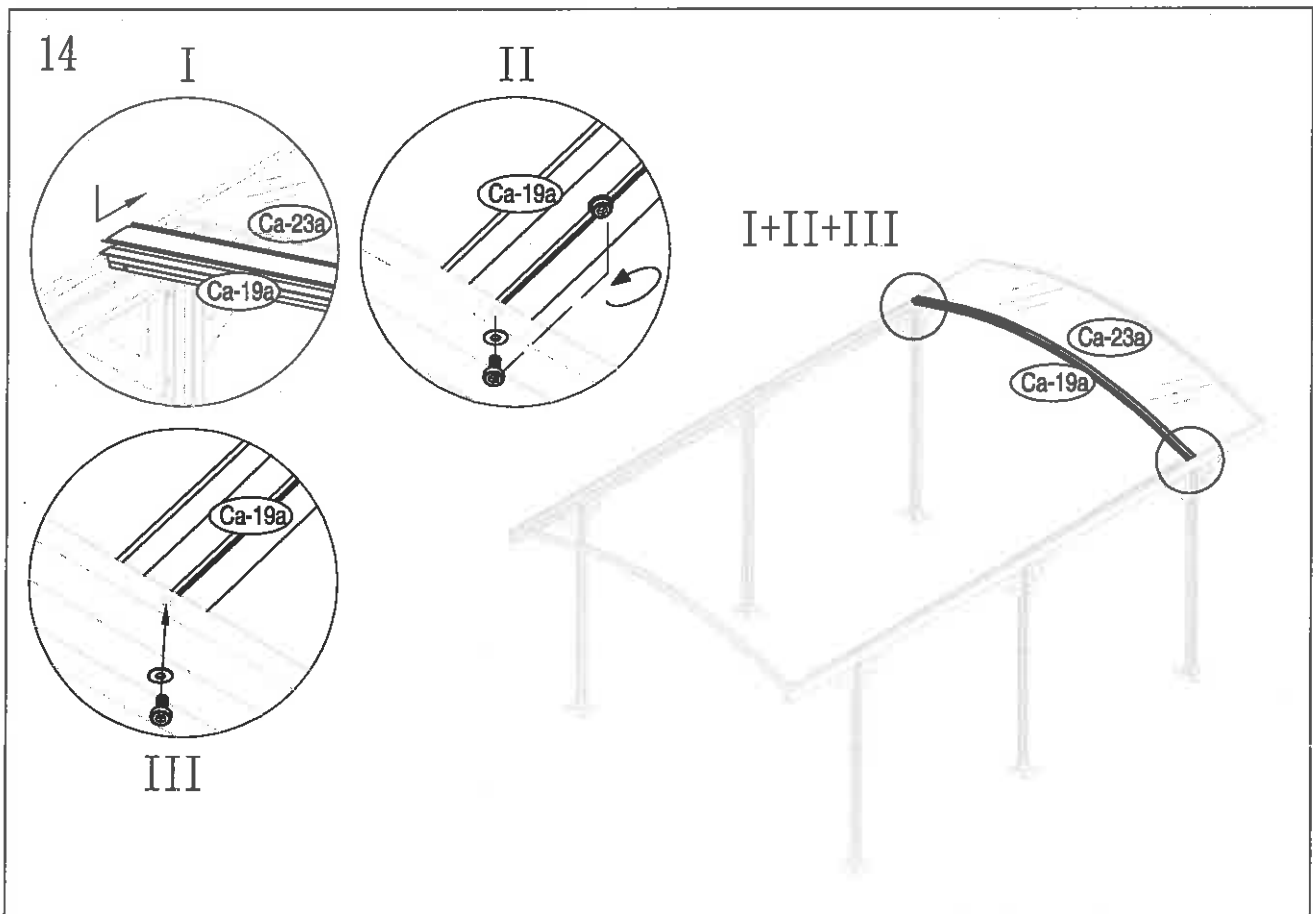
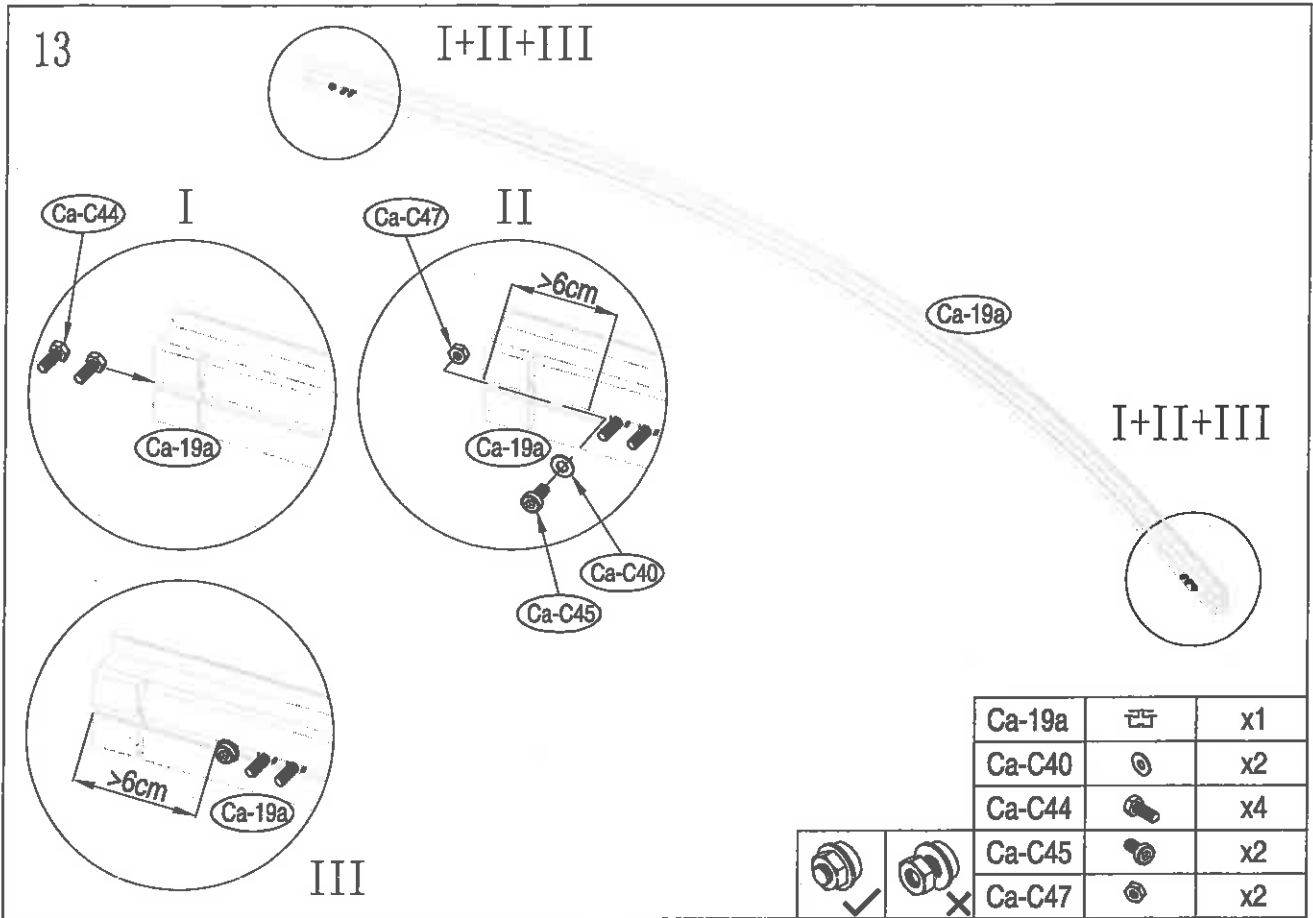

15

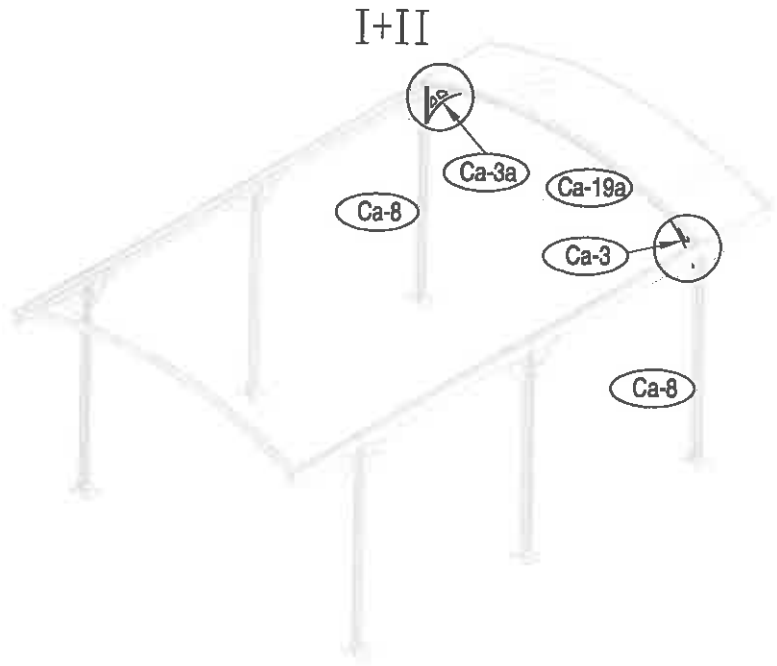
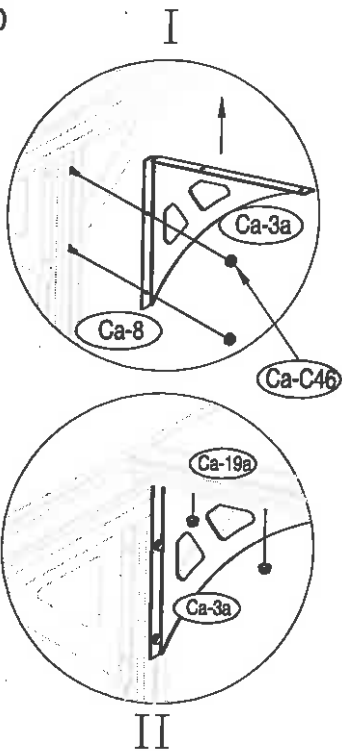

Ca-3		x1
Ca-3a		x1
Ca-C46		x8

16

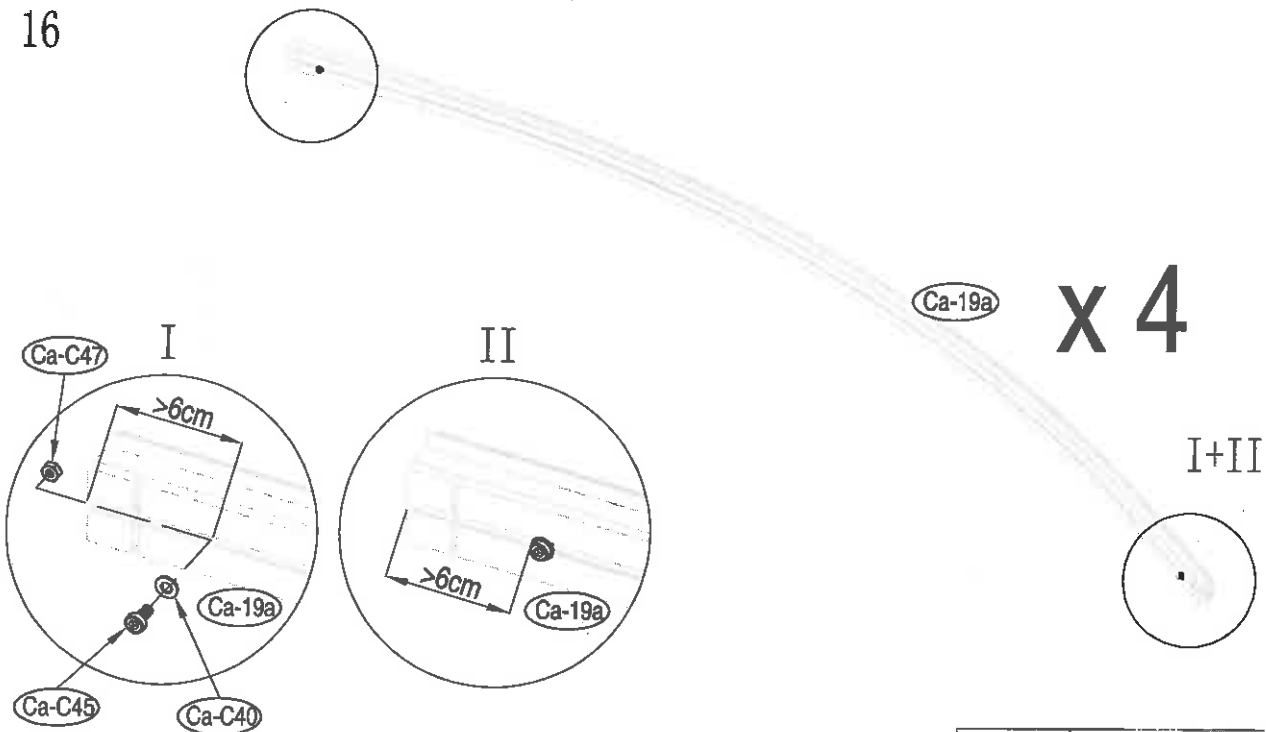

	Ca-19a		x4
	Ca-C40		x8
	Ca-C45		x8
	Ca-C47		x8

8



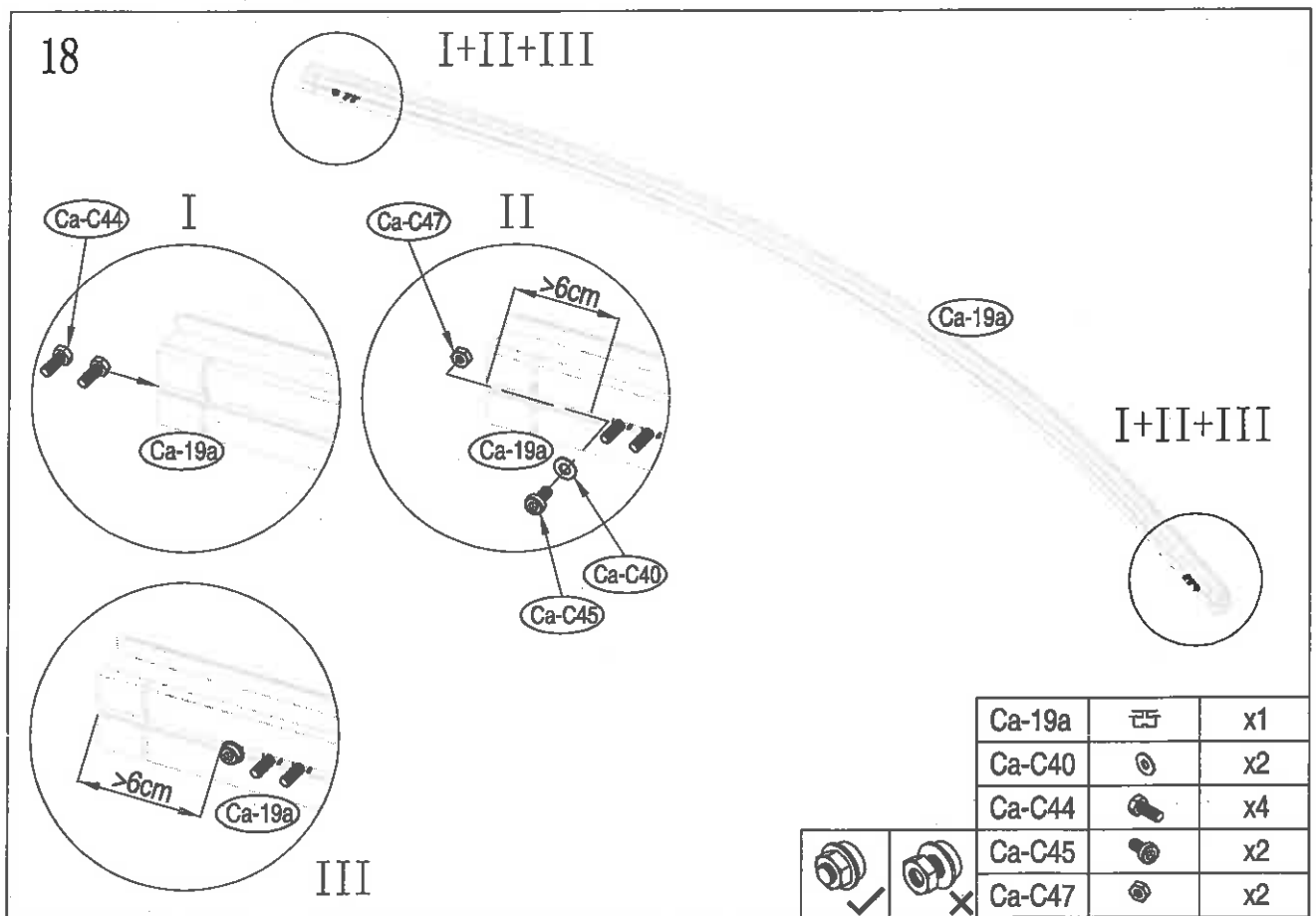
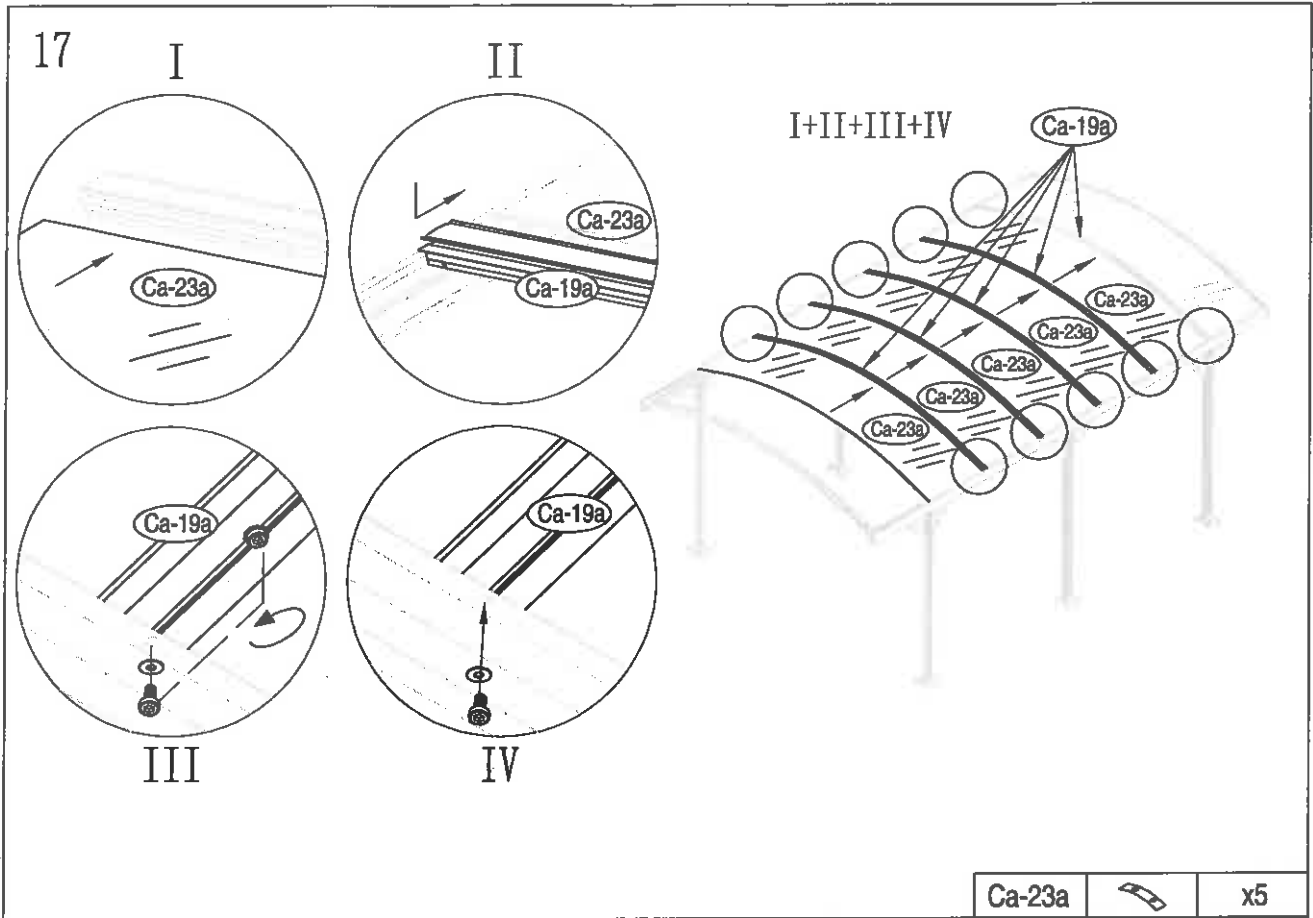



19

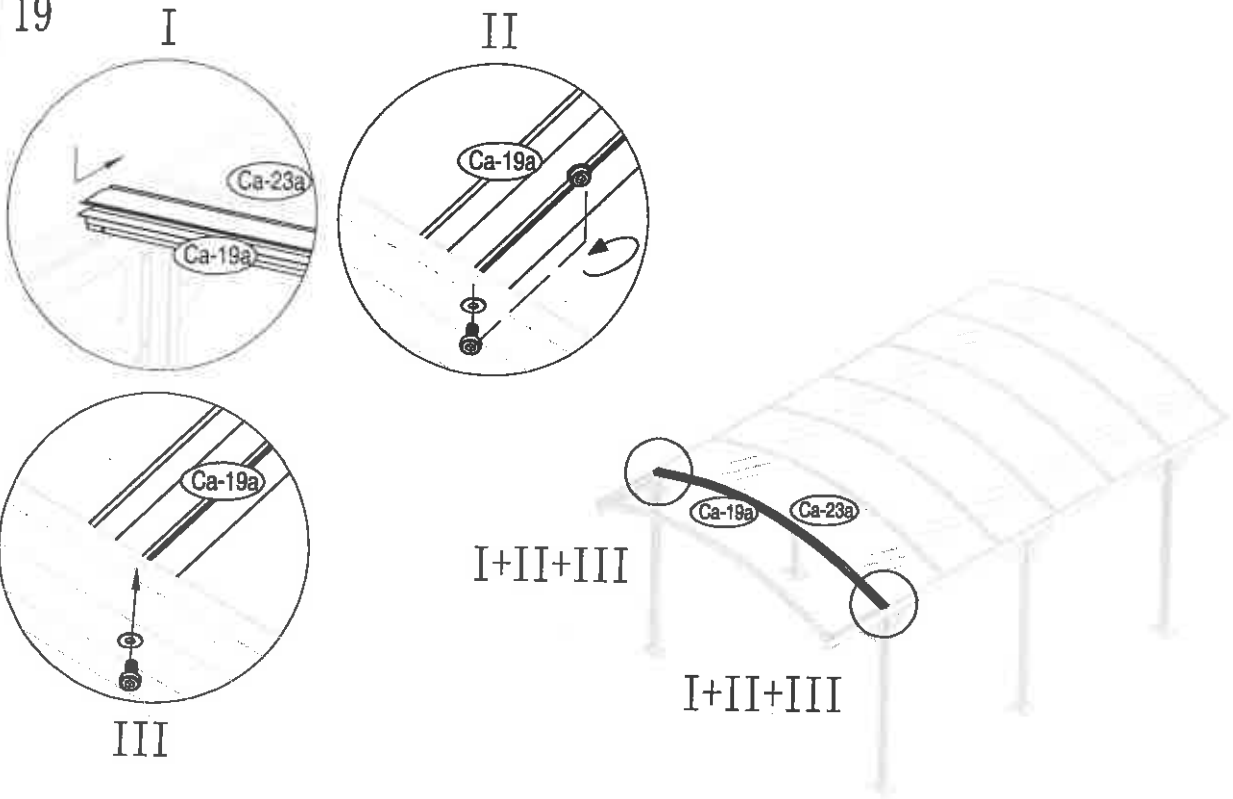

20

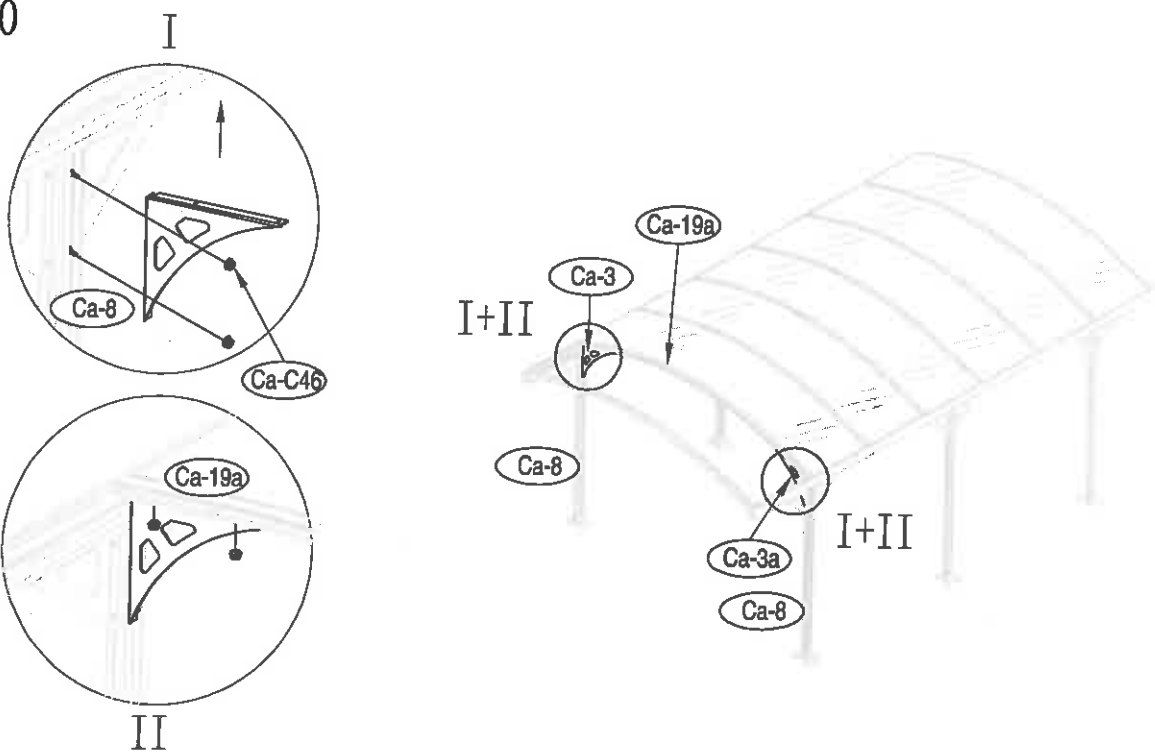

Ca-3		x1
Ca-3a		x1
Ca-C46		x8



21

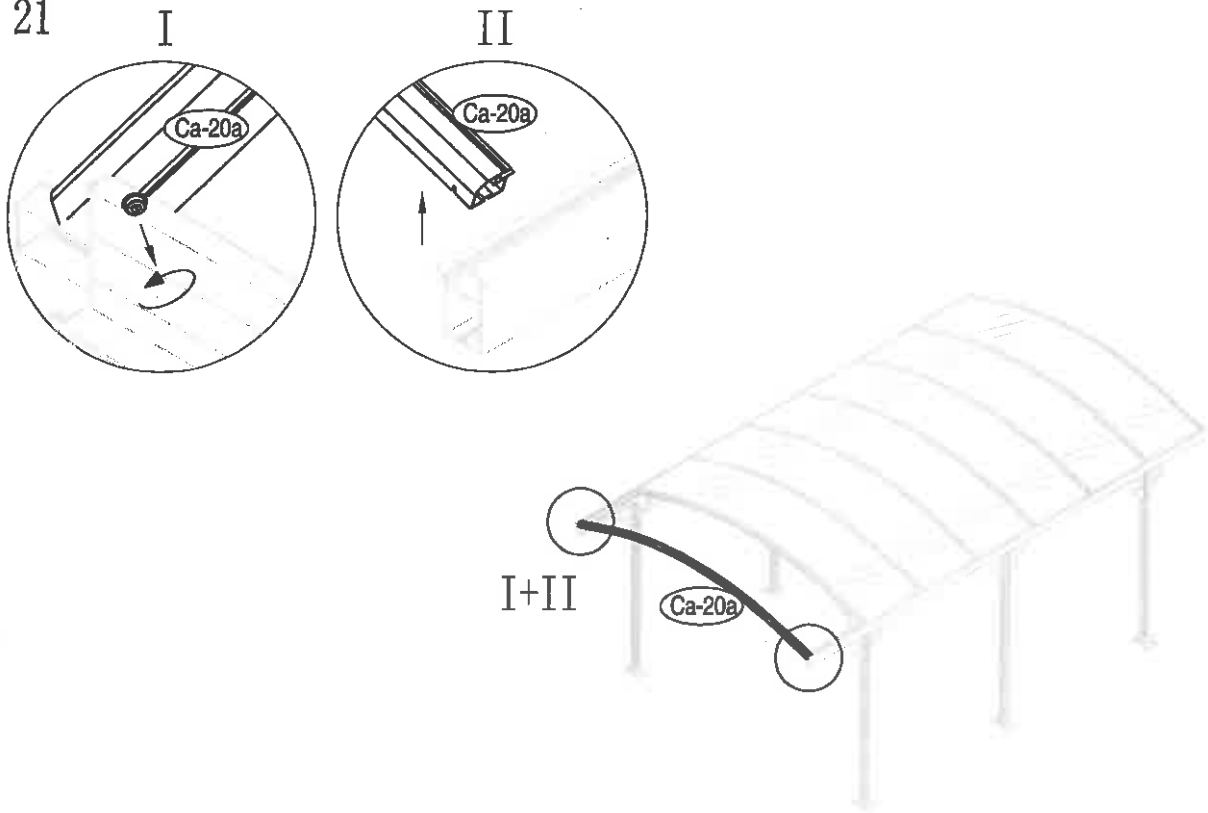

22

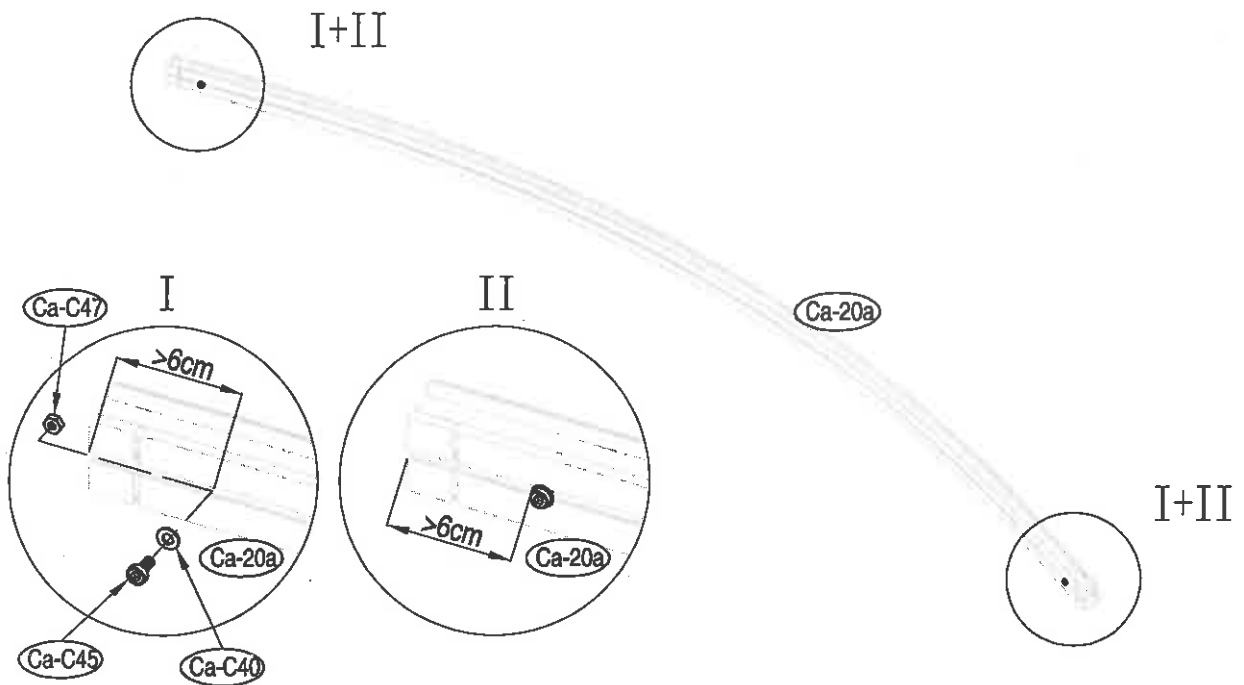

23

I

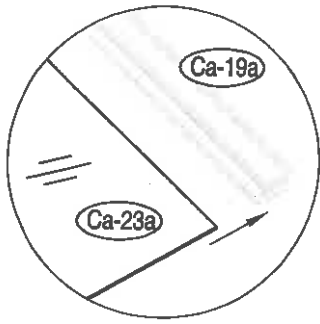

Ca-23a



x1

24

I



II

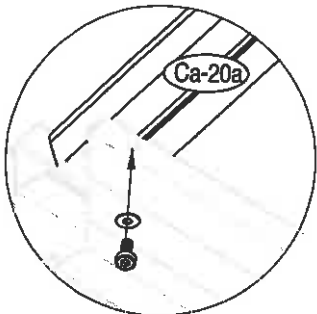
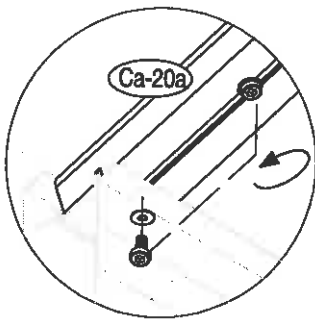

III

I+II+III

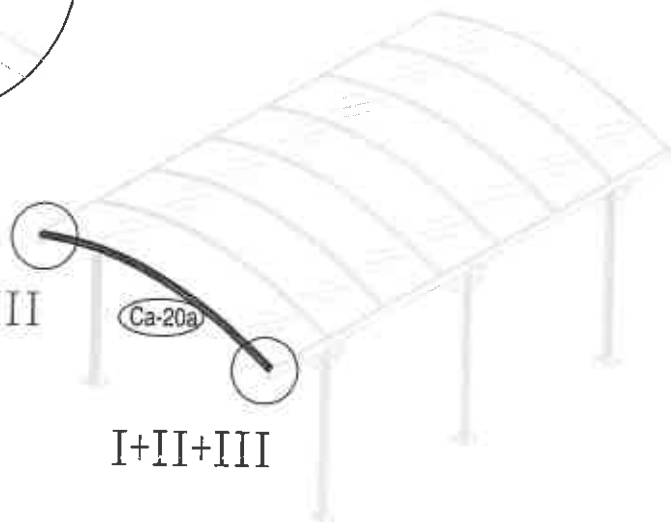

I+II+III



25

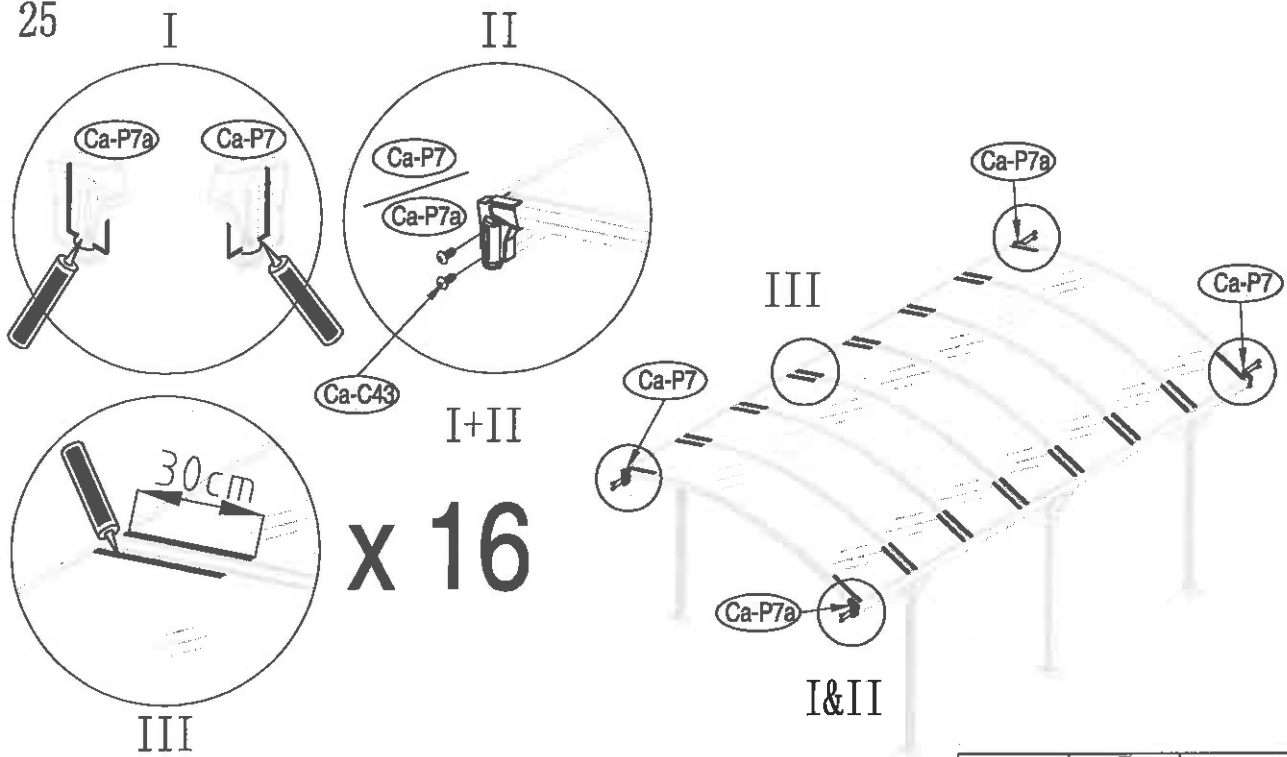

I+II  
**x 16**

Ca-P7		x2
Ca-P7a		x2
Ca-C43		x8

26

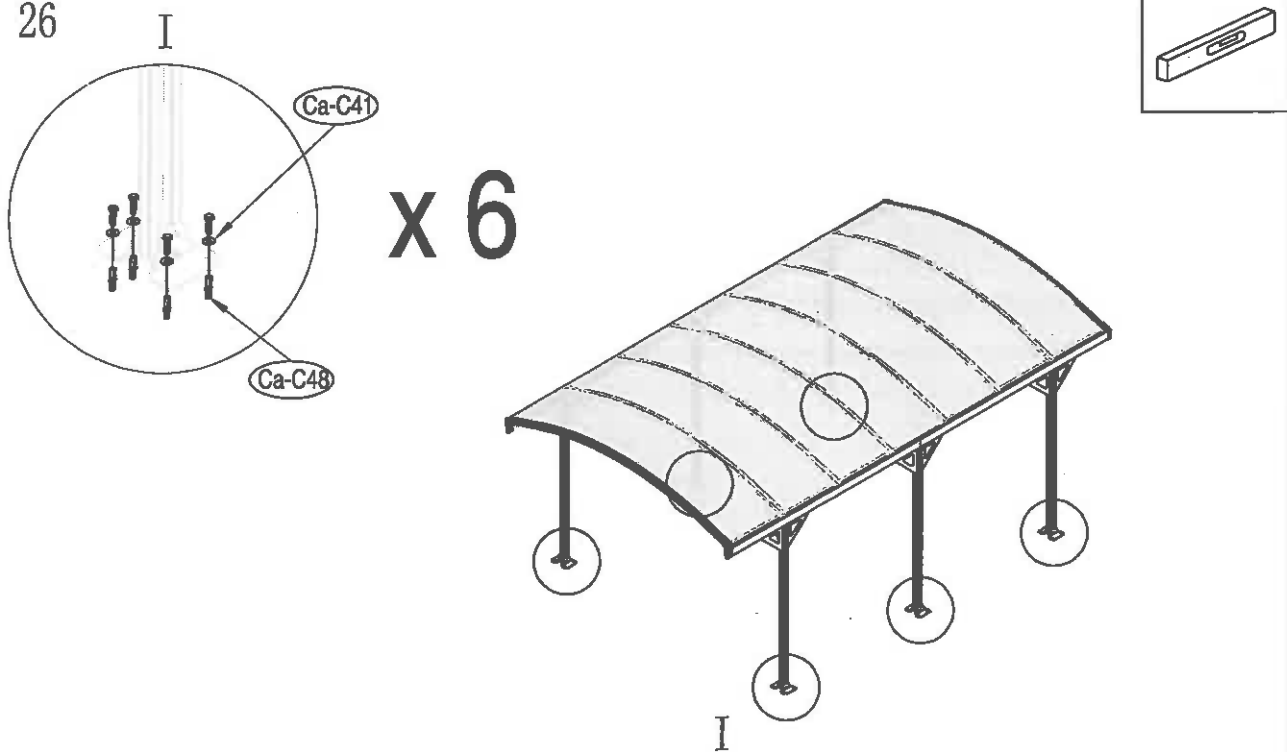

**x 6**

Ca-C41		x24
Ca-C48		x24



27

I

II

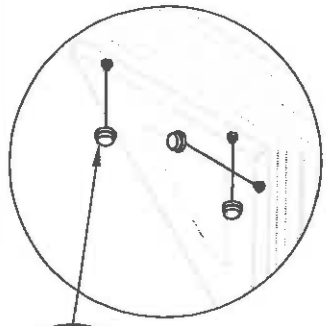

Ca-C49

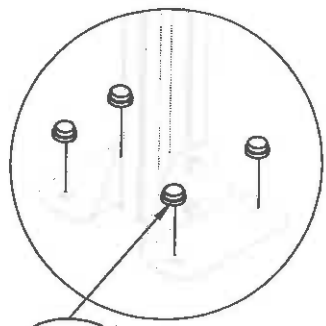

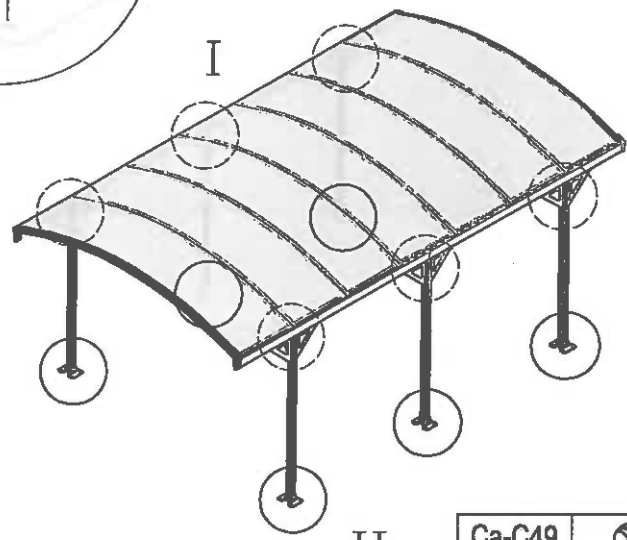

Ca-C50

x 6



II

Ca-C49		x88
Ca-C50		x24



